



ALUMINIUM

GATE RANGE

TABLE OF CONTENTS

02 WHY ALUMINIUM?
A look at the benefits of using aluminium for gates instead of wood.

03 FEATURES
Highlighting the areas we have been able to innovate with the design of our gates.

04 GATE COLLECTION
Our most popular designs, collated with ideas for alternative customisations.

16 MODERN VS. TRADITIONAL
Considering the choices that can be made to alter the aesthetic of the gates in order to attain a more modern or traditional look.

17 HORN OPTIONS
Customise any of our designs with a range of horns.

18 CLADDING OPTIONS
Transform the appearance of our gates with a selection of cladding options.

19 QUALITY & SERVICE
The ethos behind our rigorous standards.



WHY ALUMINIUM?

Our aluminium gates have been designed to replicate the positives of their hardwood equivalents whilst eliminating the negatives.

The results are chunky 140x60mm frames, classic rebates and traditional cladding options, all painted to any RAL colour.

There is no risk of warping, twisting or splitting. No more swelling or shrinking. Crucially, our gates will look as good in 10 years as they do on day one, without the need for extensive maintenance.

We are proud to offer completely British-made gates and that distinction comes with the exacting standards expected of products made in the UK.

FEATURES

The hinge ends of our gates have been designed with rounded edges. This allows the gate to pivot without a reducing gap, providing inherent safety-compliance.

Our traditional rebate allows the gates to seamlessly interlock. This rigidity is paired with an aesthetic that emulates traditional hardwood joinery techniques.

Lighter, thinner aluminium is often screwed and bolted. However, for a smooth and seamless finish that provides the strength and rigidity we require, all of our gates are fully welded as standard.

We have been able to reproduce the noticeable difference in durability and density between hardwood and softwood by opting for a heavy gauge (3.5mm) thickness for our frames. The difference in quality in comparison to the European alternatives is immediately apparent in both look and feel.

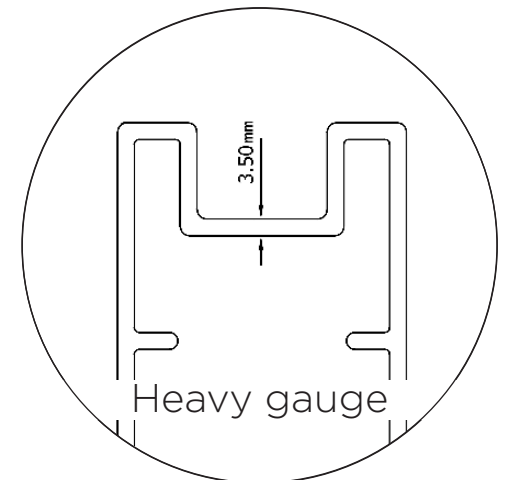
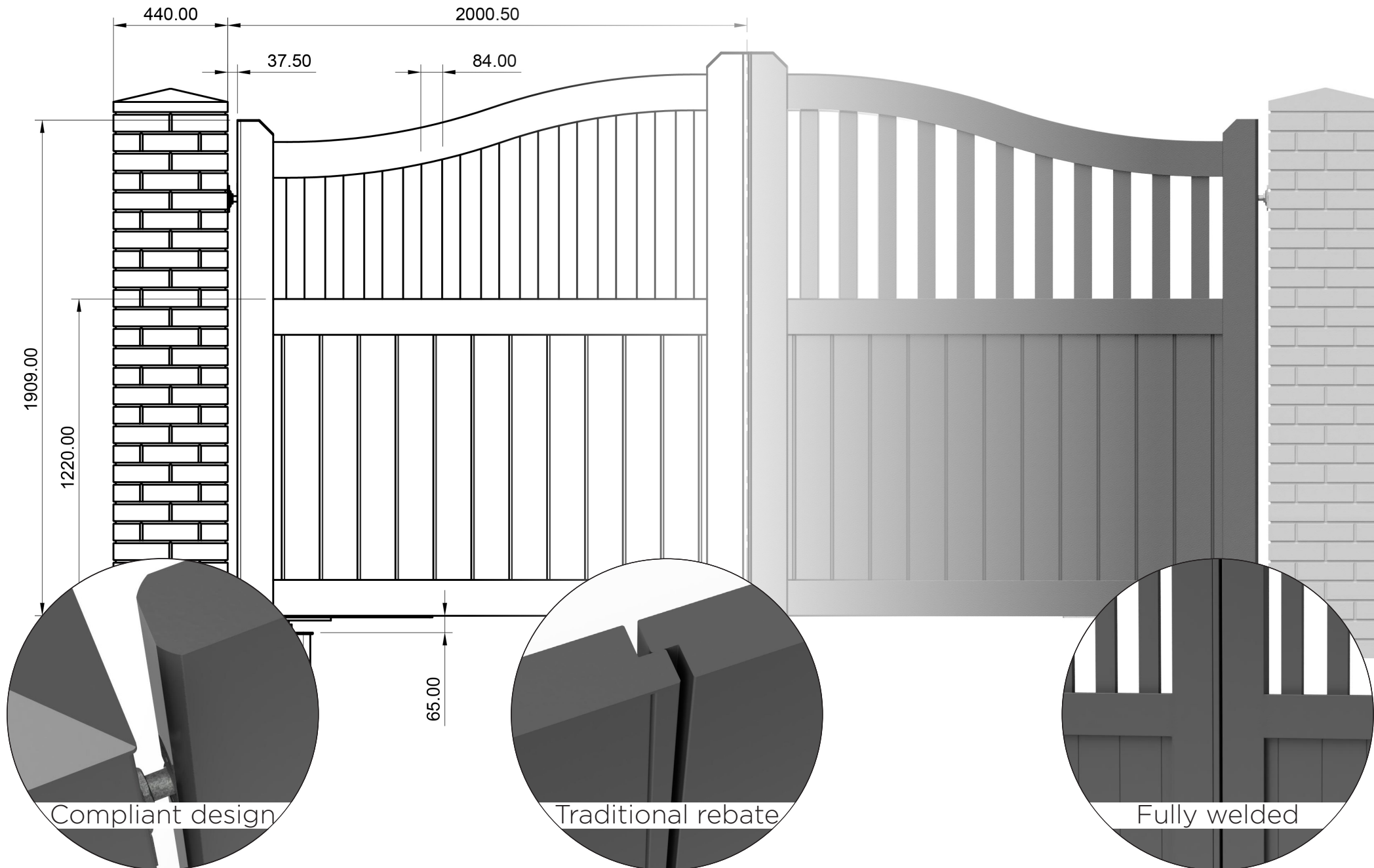

Compliant design

Traditional rebate

Fully welded

Heavy gauge

BURFORD

The elegant curves of this classic design break up straight lines and allow for increased privacy. The upward curve can also be inverted to create a drop in the middle.

Shown above with beaded cladding and rounded horns.

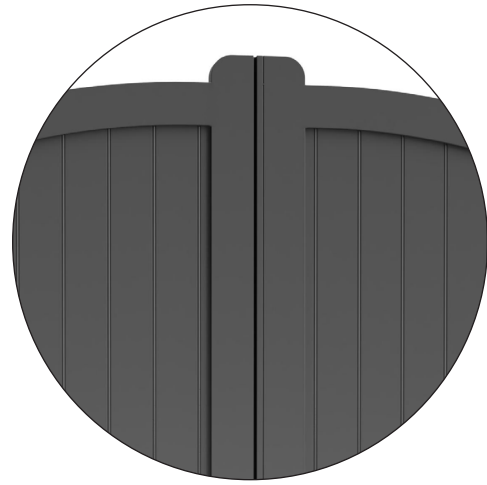

GLEBE
HOUSE



KINGHAM



The swan neck curve matched with the spindled top third combine for a traditional and welcoming entrance. As with the Burford gates, the top rail curve can also be inverted.

Shown above with drop curve horns.





CLIFTON

This flat top, fully cladded gate is perennially popular: fitting perfectly at the front of any property. A clean, understated and timeless design.

Alternate version shown above with horizontal cladding and angled horns.

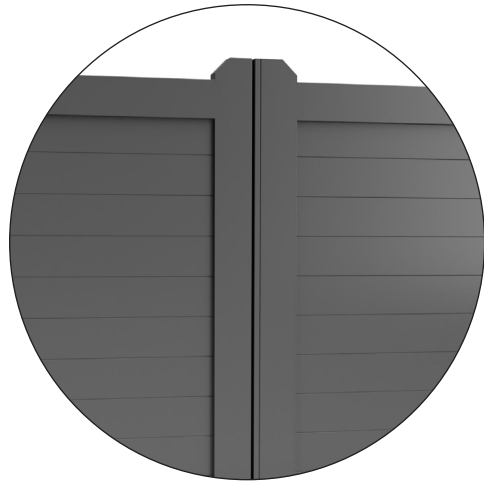



Logo
10000

FIFIELD

An attention-grabbing set of gates with numerous options for customisation. The spindles could start at any height or can even be positioned horizontally down the side of each leaf.

Shown above with beaded cladding and bird's mouth horns.

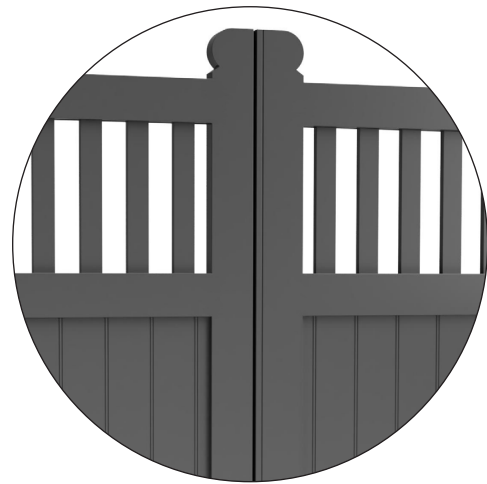



ATWORTH

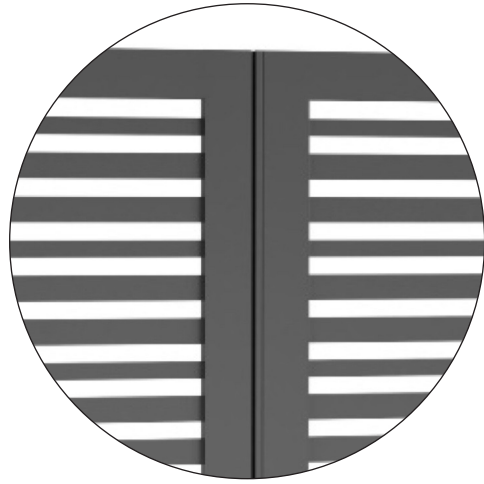

Perfectly suited to modern properties, these contemporary gates make a statement. The cladding can be fitted horizontally or vertically, with a range of different widths to choose from.

Shown above with a mixture of cladding sizes (50mm, 75mm and 100mm).





OXHILL

These classic five bar gates are often shorter and wider than our other designs. The Oxhill's blend of functionality and traditional charm offers the perfect choice for farms and modest entrances.

Alternative version shown above with rounded horns.

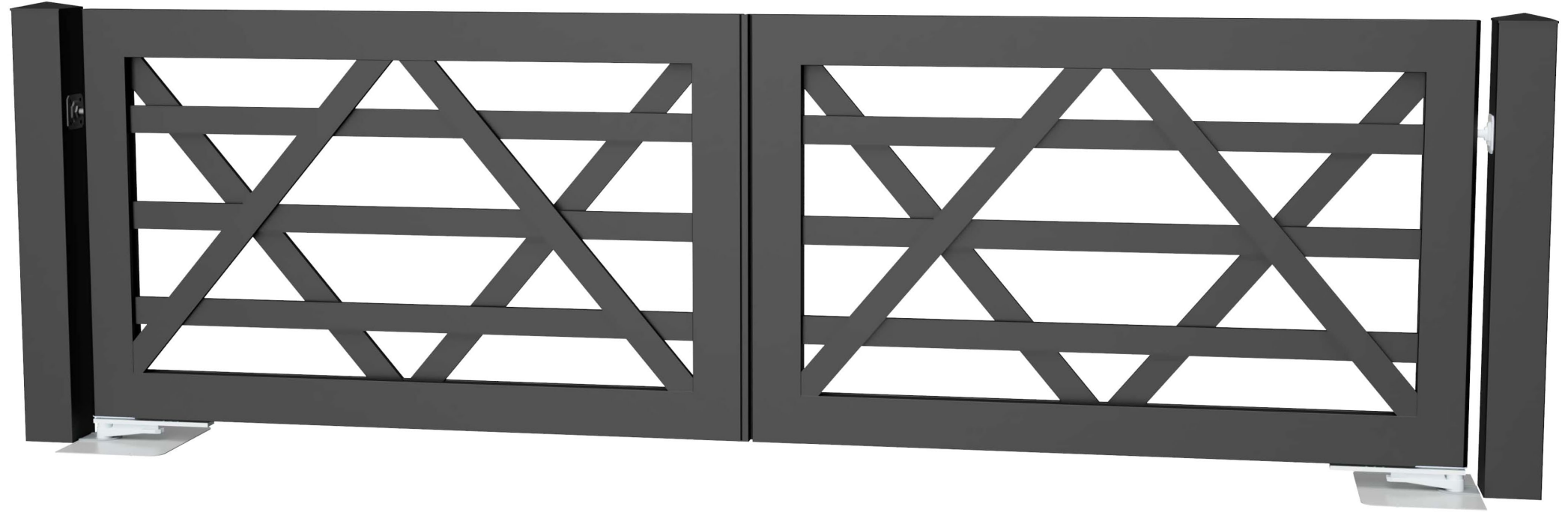
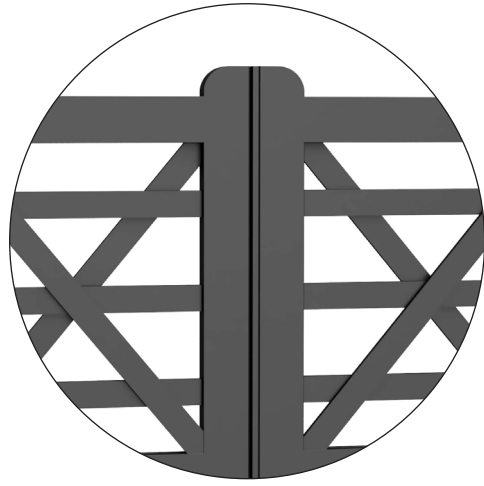





MODERN VS. TRADITIONAL

The left hand gate leaf is shown here with our chamfered cladding, fitted horizontally instead of vertically. The top of the leaf is clean and simple, without any horns. This offers a contemporary, modern look.

The right hand side, in contrast, is shown with our beaded cladding: this time fitted vertically. The top of the leaf is then finished with bird's mouth horns to create a more traditional looking gate.

HORN OPTIONS

The finer details in any design often make the biggest difference. Our range of horns provide the perfect opportunity to customise the look of each gate.

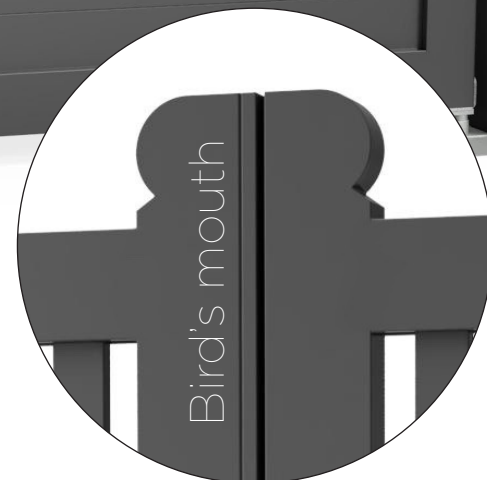
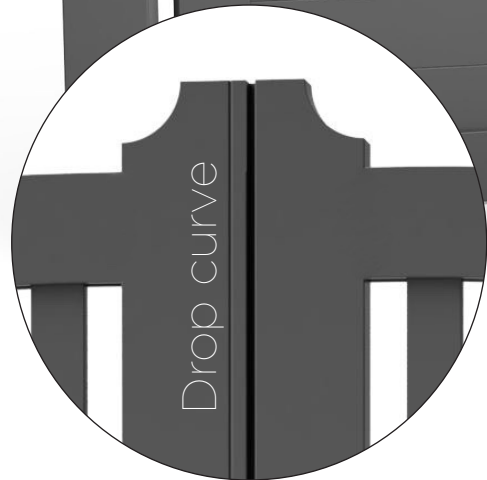

CLADDING OPTIONS

Our chamfered cladding provides the classic tongue and groove look, particularly when fitted vertically. For modern properties, or to achieve a more contemporary looking gate, the cladding can be fitted horizontally. It's a simple, yet very effective adjustment that can give an entrance an entirely different aesthetic.

To really bridge the gap between the modern benefits of aluminium with the conventional appearance of wood, our beaded cladding offers the best of both worlds. This classic design is perfect for attaining a traditional finish.

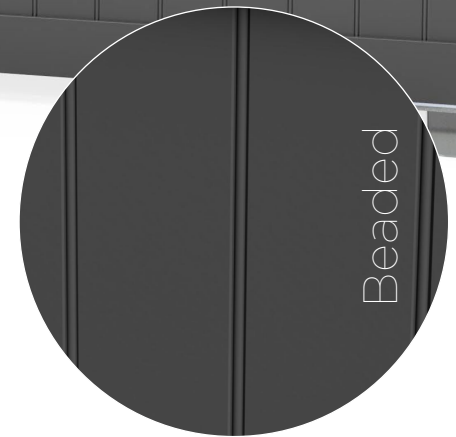
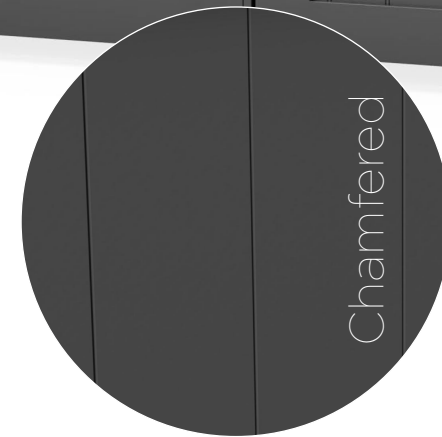



QUALITY & SERVICE

We recognise the importance of having a product that can be relied upon, delivered by a team that genuinely cares about the customer experience. Our commitment to the highest possible standards of quality and service are what makes this possible.

Each choice we make in the construction of our gates is based on what will produce the most premium end product. As such, our aluminium gates are built to withstand the test of time and our warranty reflects this.

Any issues with the build or manufacture of our gates are covered by our 10 year warranty. For any standard installations, the same 10 year warranty applies for our paint finish. You can rest assured that a set of our aluminium gates is a choice for long-term quality that is unmatched in the industry.